

MagnaBoard®

MagnaBoard® Wall Panel (30 minute Fire Rating SANS 10177P 2-2005)

Fire Test Report #: 2538 / FPE / 85258 / 10

- Symmetrical construction using 1 x 9 mm MagnaBoard on either side of frame
- 63.5 x 25 x 0.5 mm drywall tracks suitably fixed to floor at 600 mm centres (and top)
- 63.5 x 34 x 0.5 mm drywall studs fixed on tracks at 610 mm centres
- 30 mm drywall screws fitted at 250 mm centres
- Fibre tape fitted over the joints
- Permabond primed to joints before gliding joints
- Rhinoglide mixed with Permabond (ratio 4:1) and water covering joints in 2 layers, or fibre tape covered in 2 layers of *papresa de Juntas*.
- Double studs used at all board joints

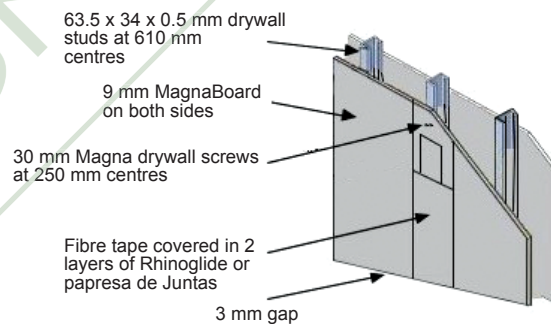
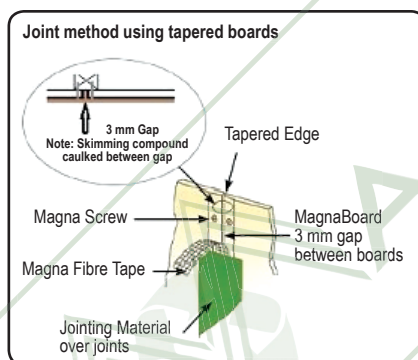

JOINTS MUST BE STAGGERED

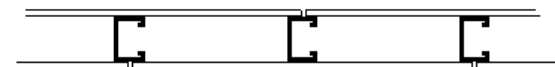

30 Minute Fire Rating Diagram